

# Assembly Instructions

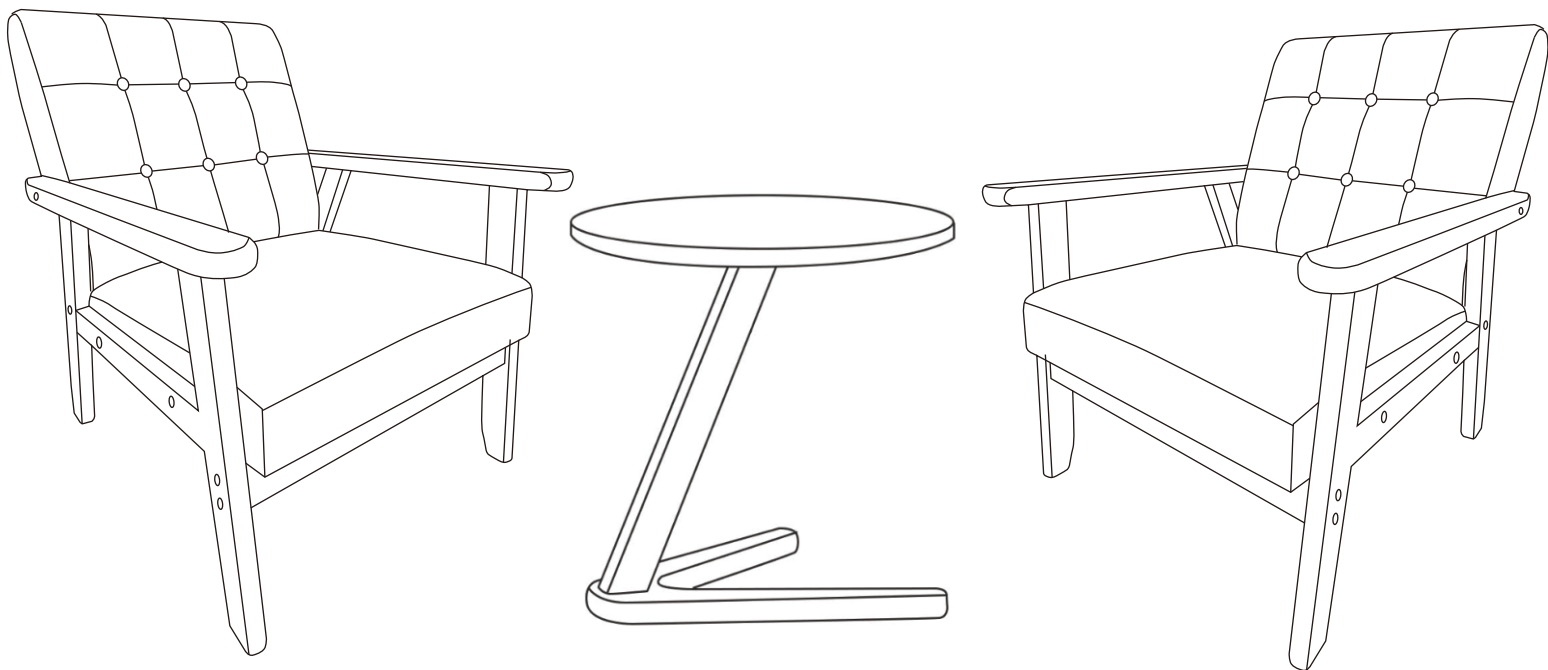

PARTS CHECKLIST

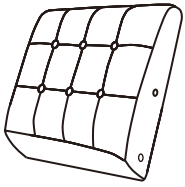

Ax2PCS

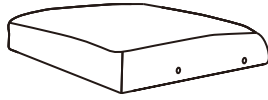

Bx2PCS

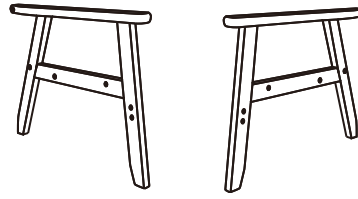

Cx2PAIRS

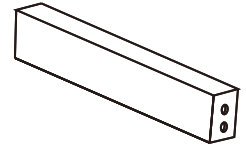

Dx2PCS



Ex24PCS

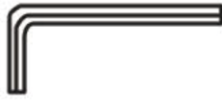

Fx1PC



Gx24PCS



Hx8PCS

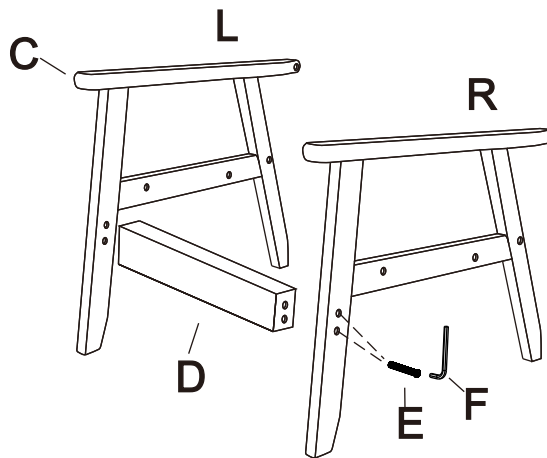

**Step 1:** Connect Crosspiece [ D ] to Armrests [ C ] with Screw [ E ]. And tighten them by 70%.

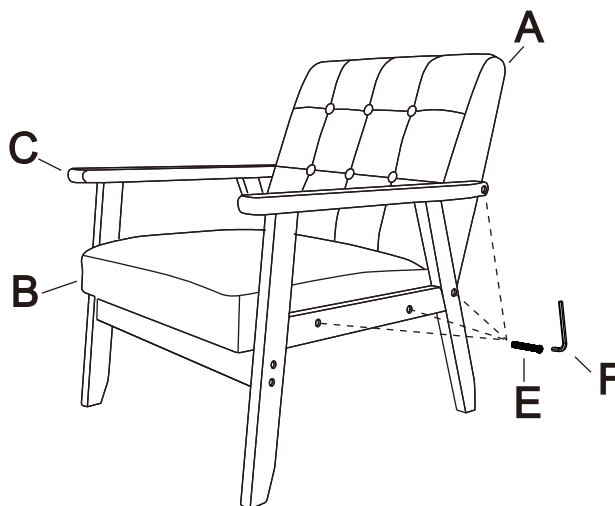

**Step 2:** Connect Armrests [ C ] to the Backrest [ A ] and Seat [ B ] with Screw [ E ]. Tighten them by 70%. Make sure the accent chair is leveled on the ground. Then tighten all the screws by 100%.

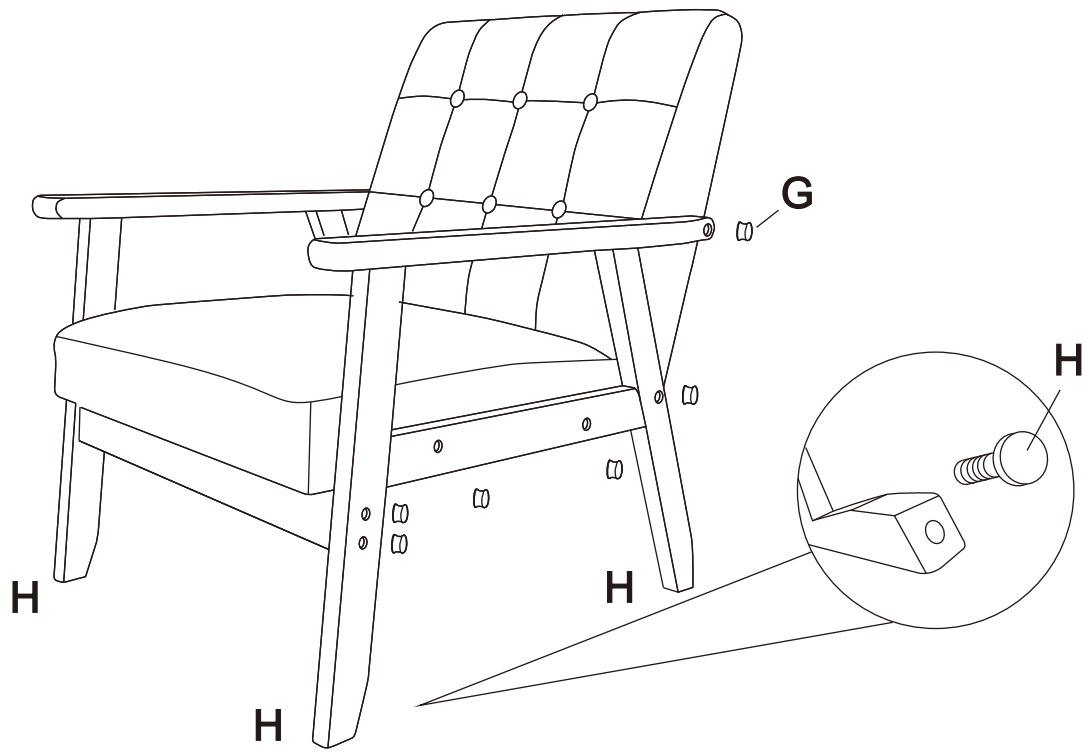

**Step 3:** Put the hole caps [ G ] into the screw holes. And install the adjusting nails [ H ] to the bottom of them .

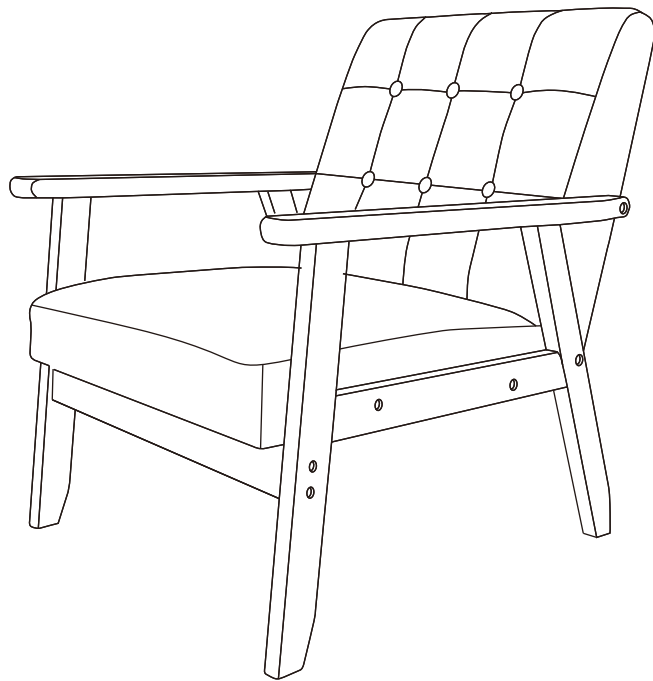

**Step 4:** Enjoy your new Accent Chair!

PARTS CHECKLIST

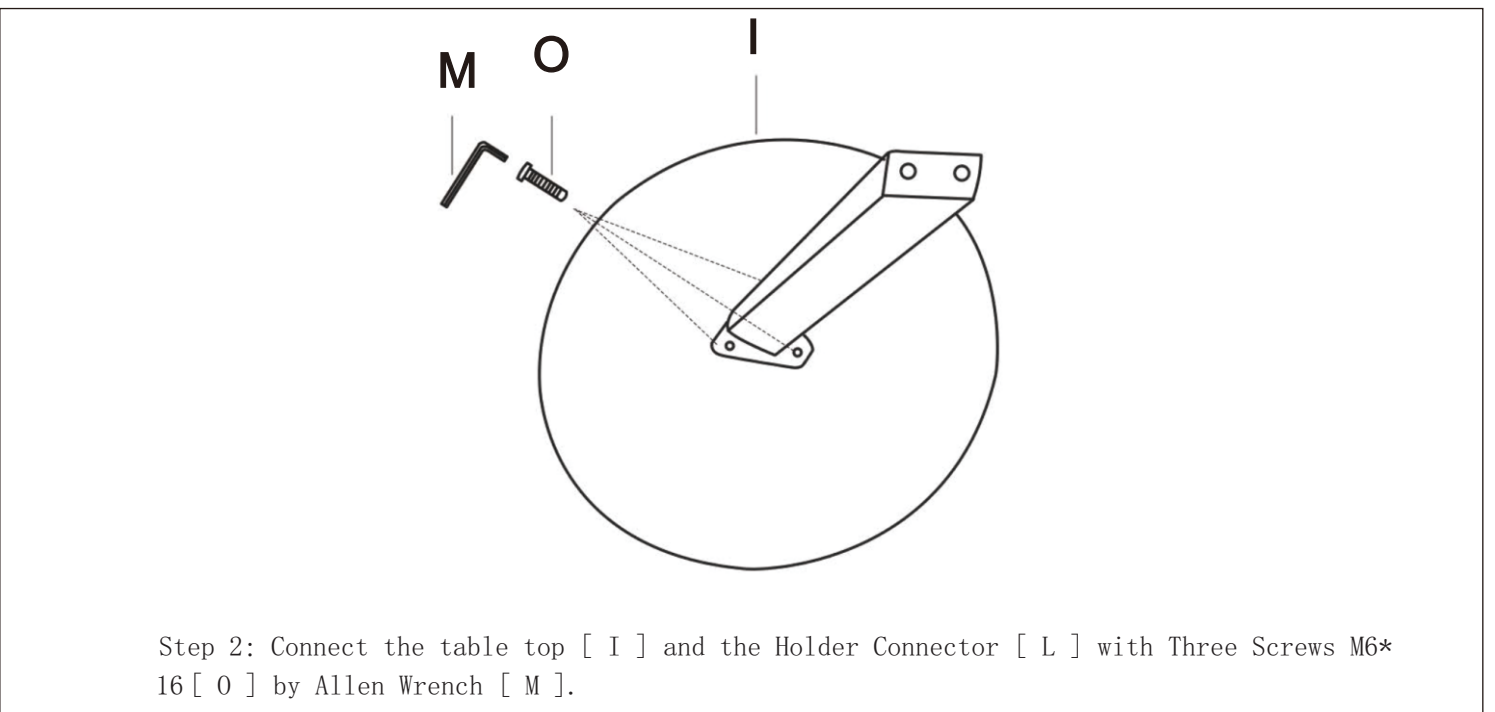
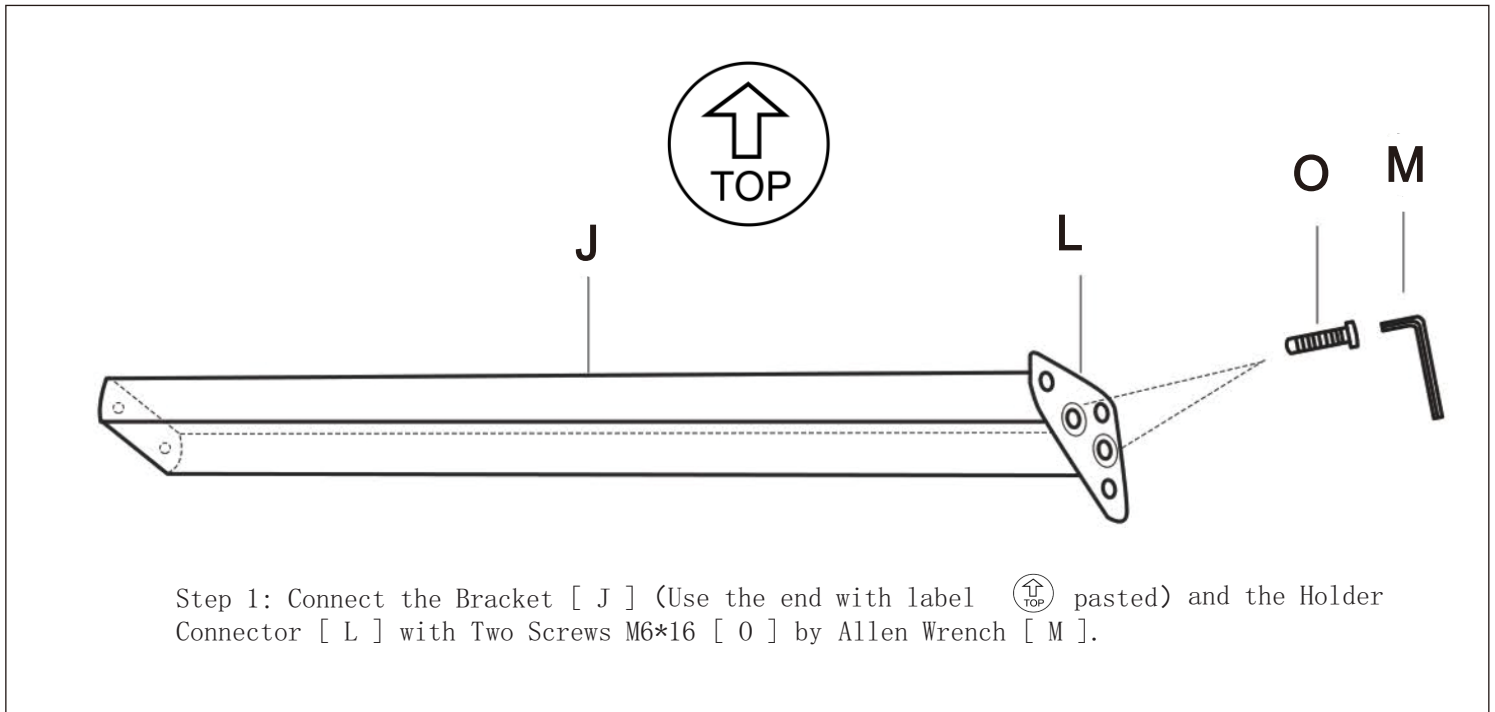
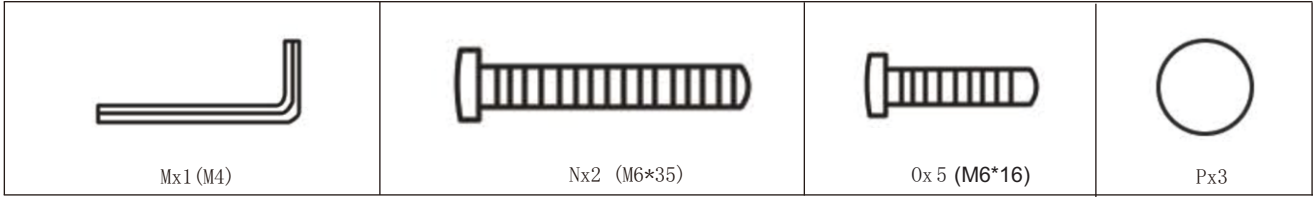
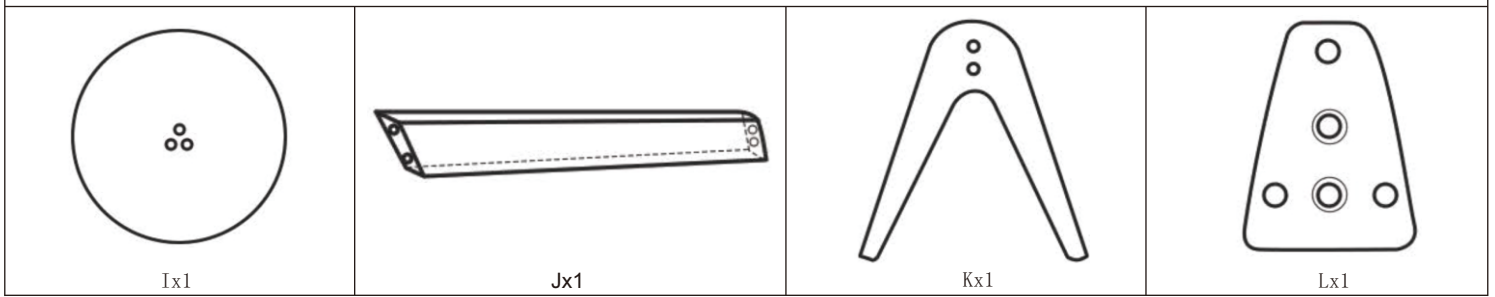

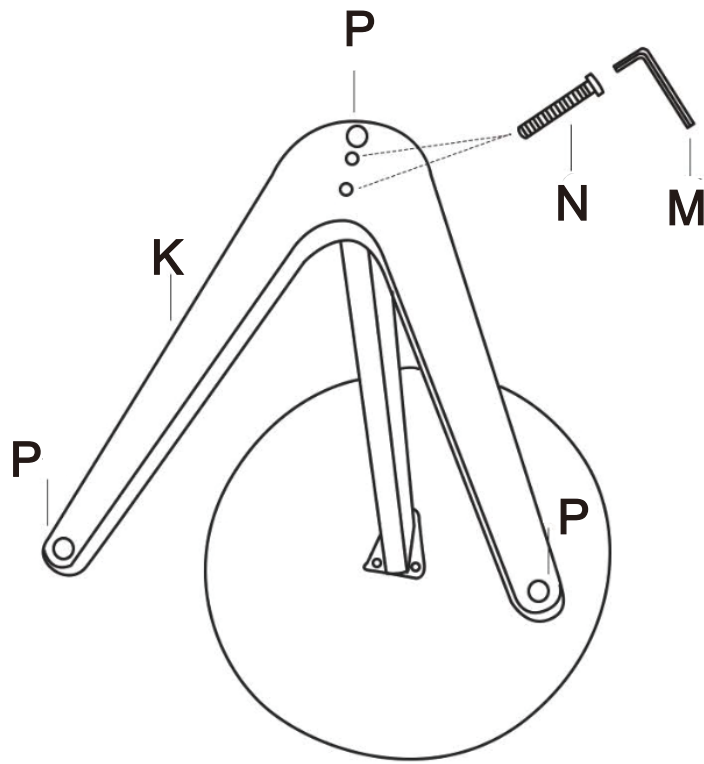

**Step 3:** Connect the Base [ K ] and the Bracket [ J ] with Two Screws M6\*35 [ N ] by Allen Wrench [ M ]. And paste the foot pad [ P ] to the bottom of base.

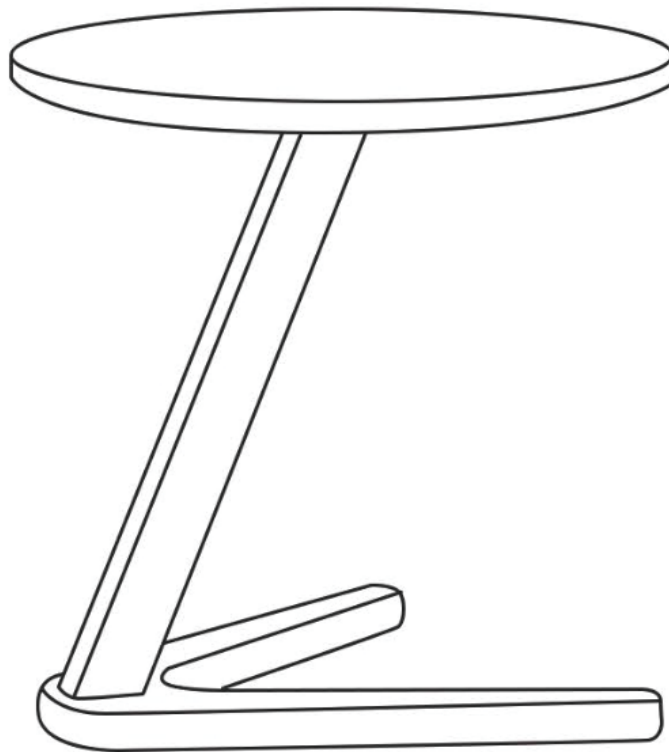

**Step 4:** Enjoy your new Table!