

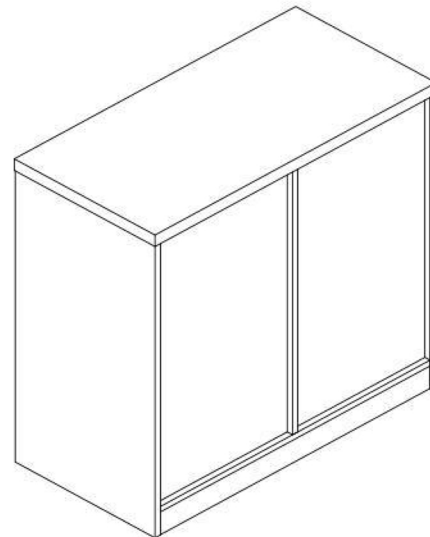

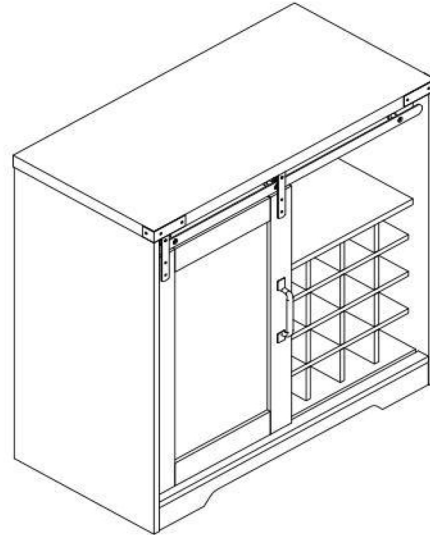











User Manual
ASSEMBLY INSTRUCTION
CD-068B





















Parts List

NO.	Drawing	Dimension	QTY
1		767*60*15mm	1
2		767*60*15mm	1
3		767*397*15mm	1
4		765*398*15mm	1
5		690*352*15mm	1
6		765*398*30mm	1
7		376*332*15mm	1

NO.	Drawing	Dimension	QTY
8		374*330*15mm	1
9		800*400*30mm	1
10		700*386*4mm	2
11		376*320*12mm	3
12		376*320*12mm	3
13		767*80*15mm	1
14		391*621mm	1

Hardware Fitting

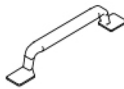
NO.	Drawing	QTY
A		33
B		33
C		3
D	 764*25*3mm	1
E	 6*55mm	3
F		3
G	 M6	3
H		1
I		1

NO.	Drawing	QTY
K		16
L	 3.0*14mm	16
M		4
N		2
O	 3.5*14mm	12
P		2
Q		4
R		1
S		2
T	 3.5*35mm 3.5*14mm	2



Split Graph

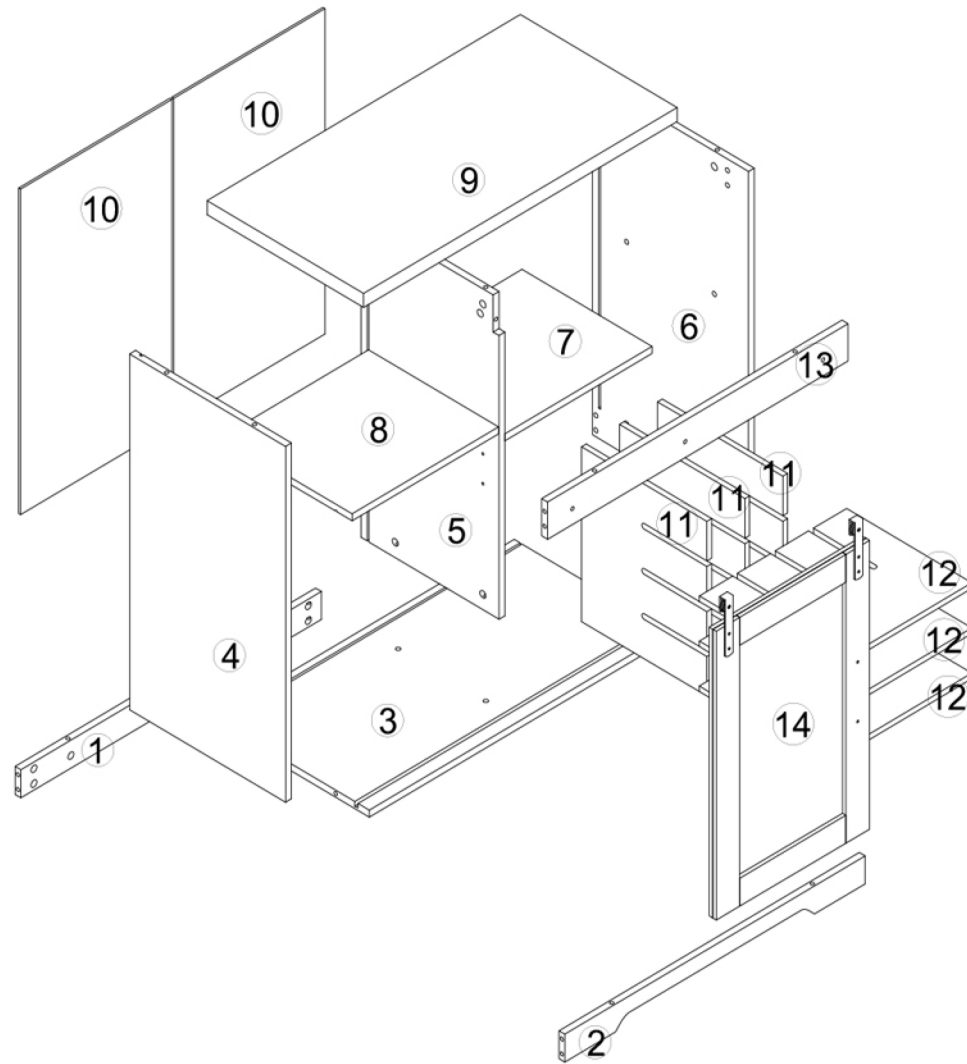

Cam Coupling Using Methods

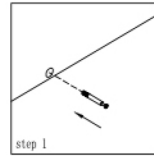

Step1.

Connect the cam coupling A as directed in the assembly instructions using hand.

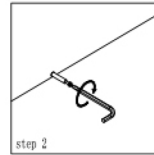

Step2.

Screw the cam coupling A as directed in the assembly instructions.

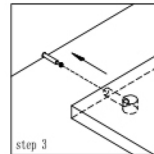

Step3.

Push the cam coupling A into the entry hole.

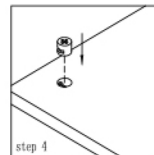

Step4.

Insert the cam coupling B as shown in the instructions.

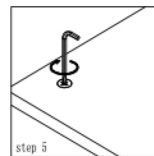

Step5.

Turn the cam coupling B clockwise with a screwdriver

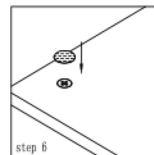

Step6.

Put on Beautycam.

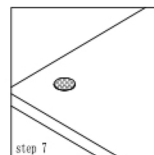

Step7.

Finished.

You should feel a click when the camlock is locked in place.
The joint is now secure.

Note: Cam Coupling Using Method,
please refer to Page 4.

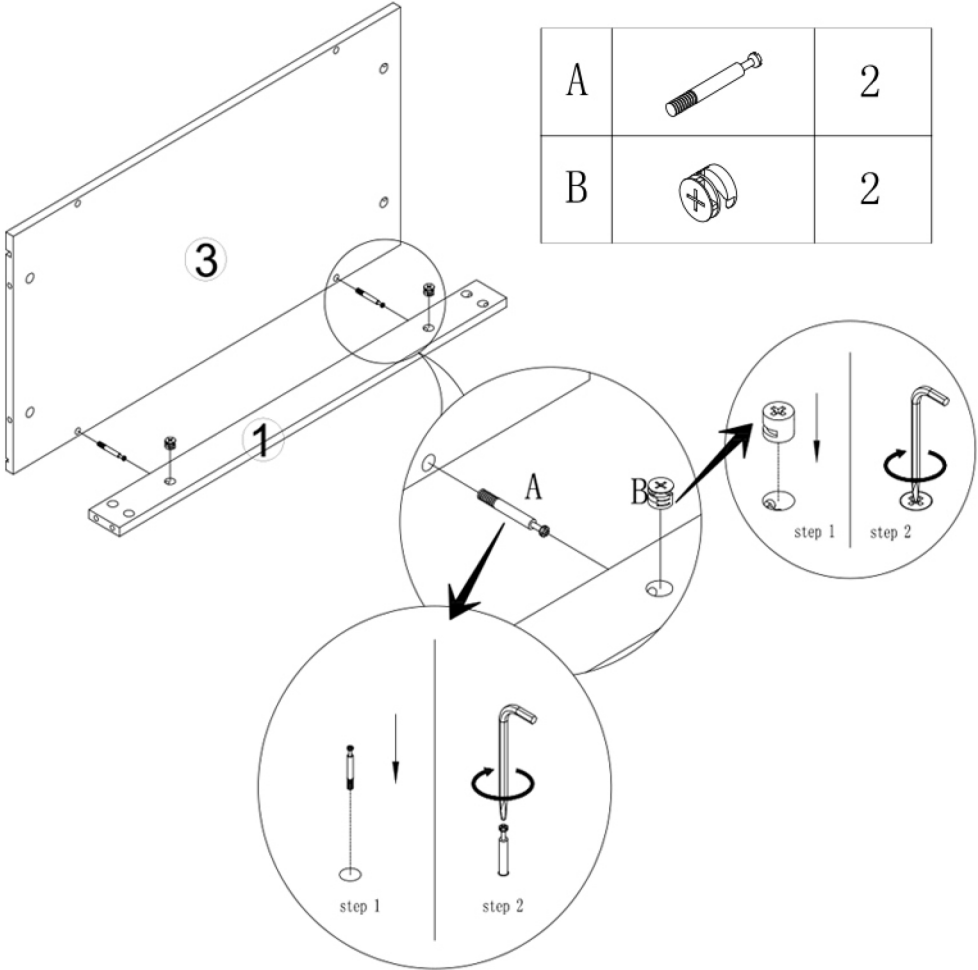





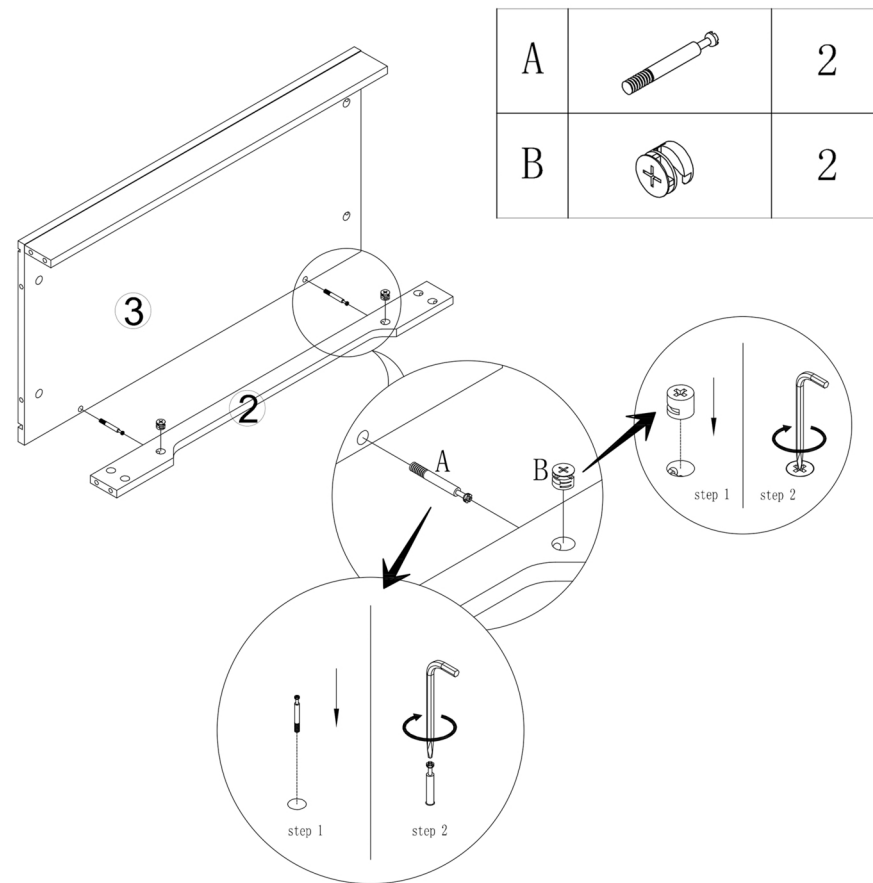

Step 1.

Connect Panel 1 to Panel 3 with Cam Coupling A&B.



Step 2.
 Connect Panel 2 to Panel 3 with Cam Coupling A&B.

C		3	H		1
D		1	I		1
E		3			
F		3			
G		3			

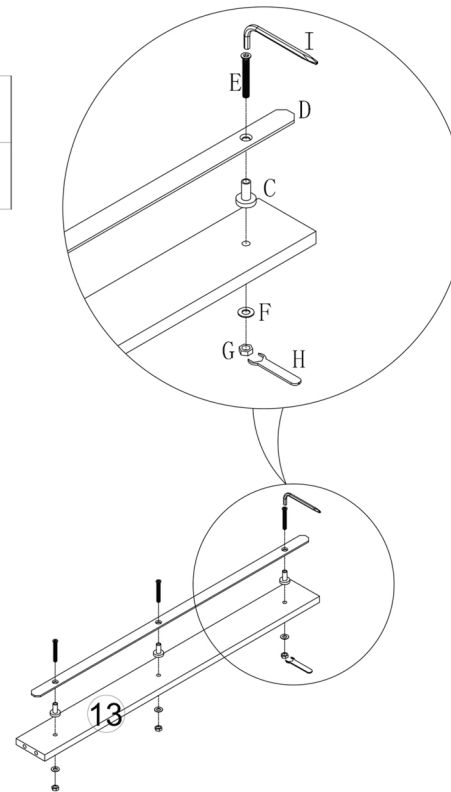

Step 3.
Fix metal part D on Panel 13 with component C, E, F, G, H, I.

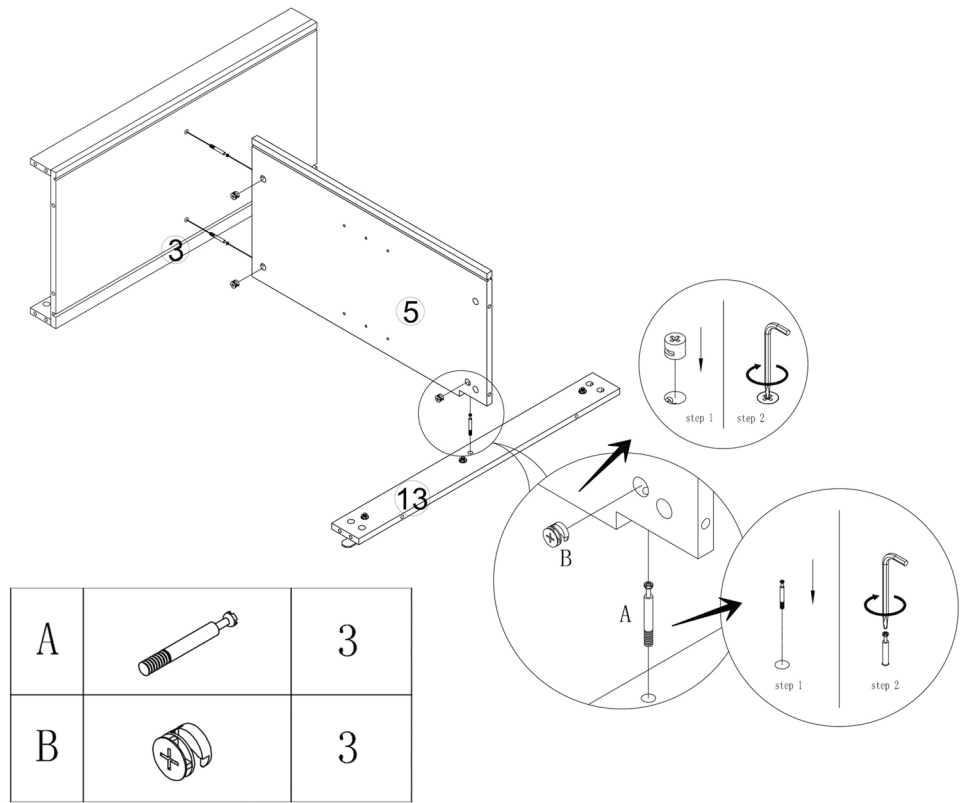

Step 4.
 Connect Panel 5 to Panel 3,13 with Cam Coupling A&B.

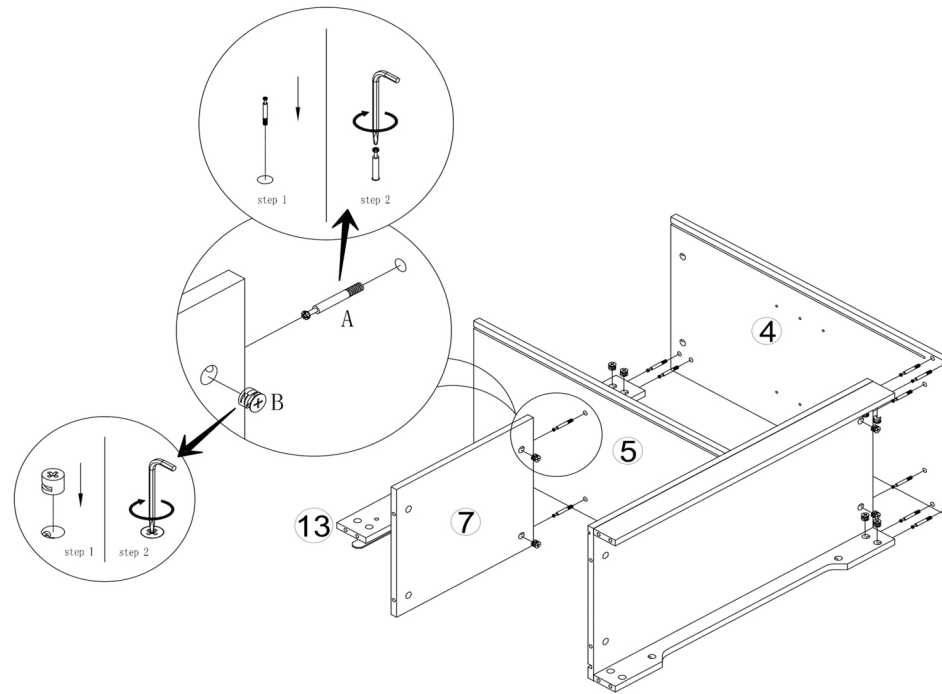

A		10
B		10

Step 5.

Connect Panel 7 to Panel 5 with Cam Coupling A&B.
 Connect Panel 4 to Panel 1,2,3,13 with Cam Coupling A&B.

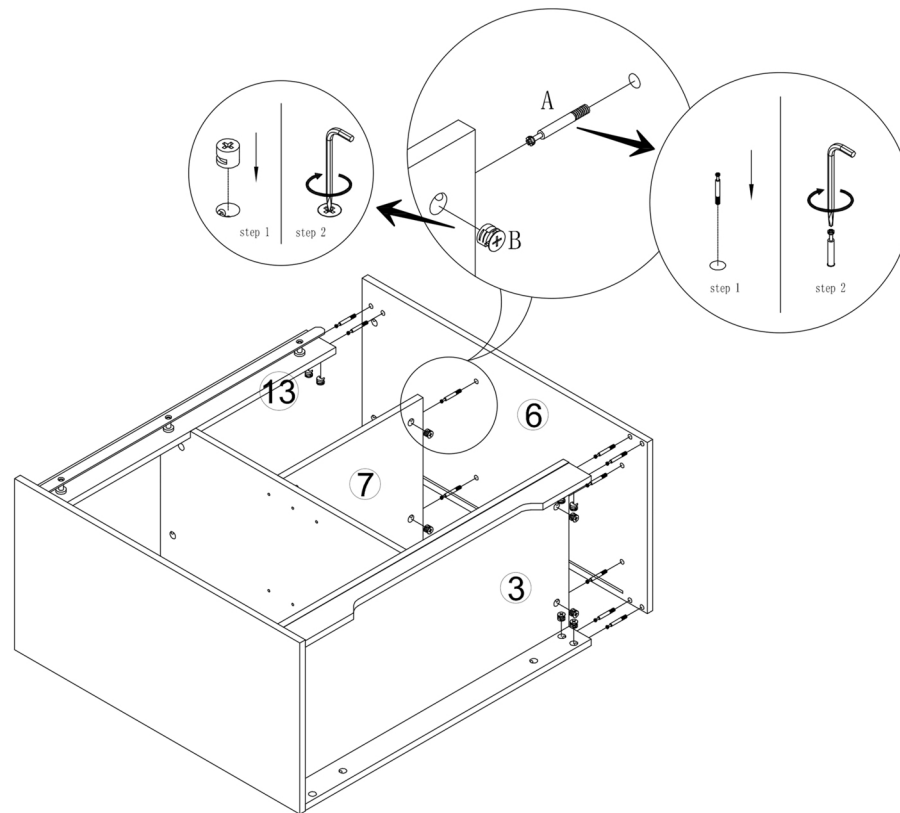

A		10
B		10

Step 6.
Connect Panel 6 to Panel 1,2,3,7,13 with Cam Coupling A&B.

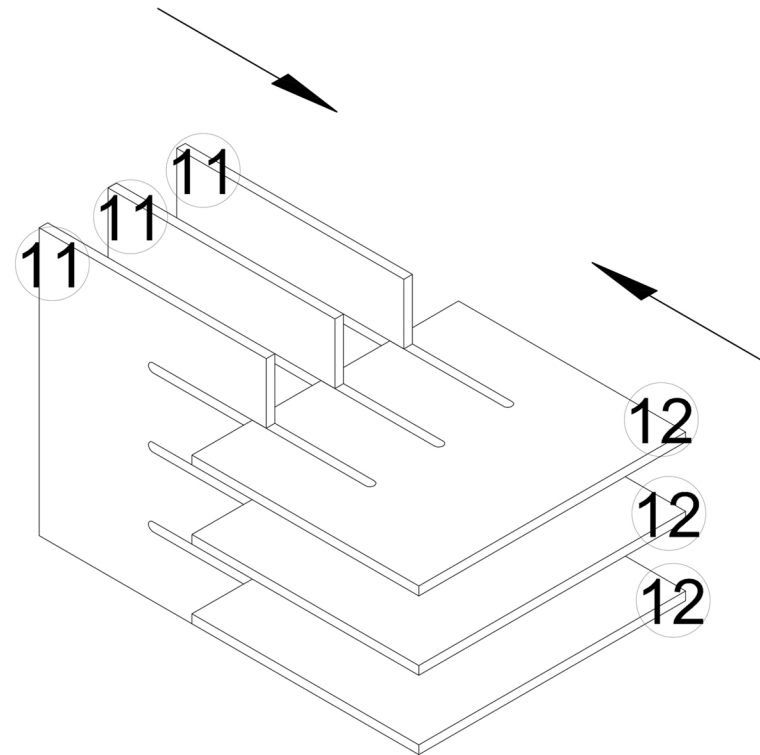

Step 7.
Insert 3PCS Panel 11 into 3PCS panel 12 separately.

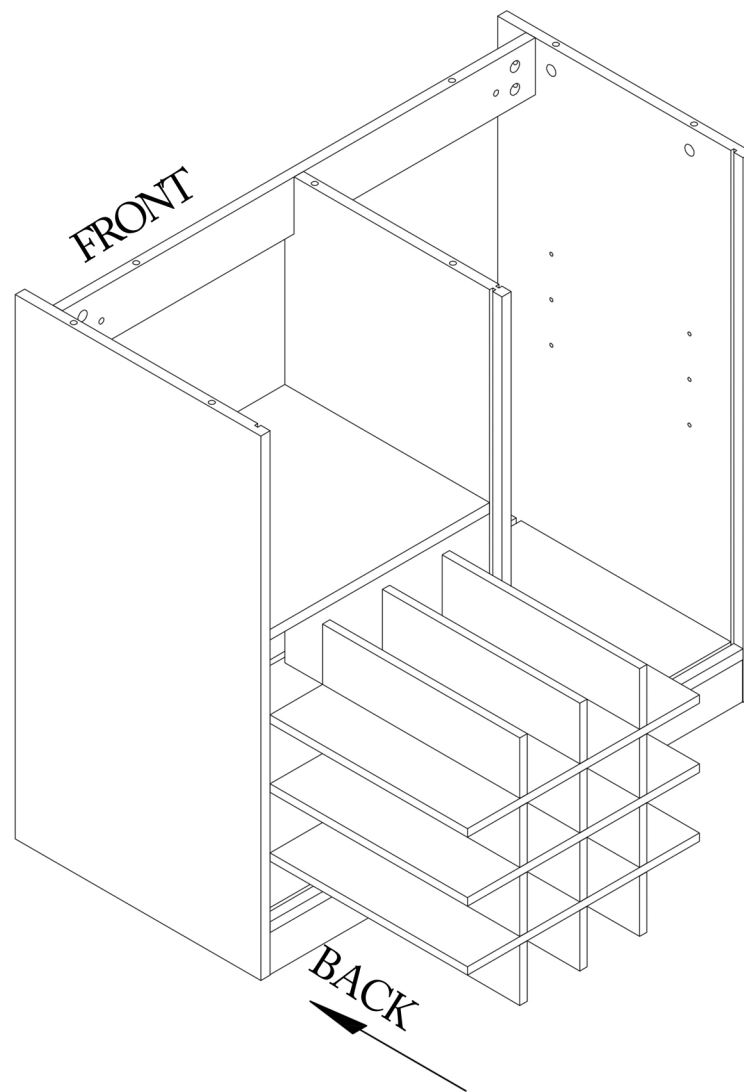

Step 8.

Insert the whole Panel 11,12 into cabinet body from back.

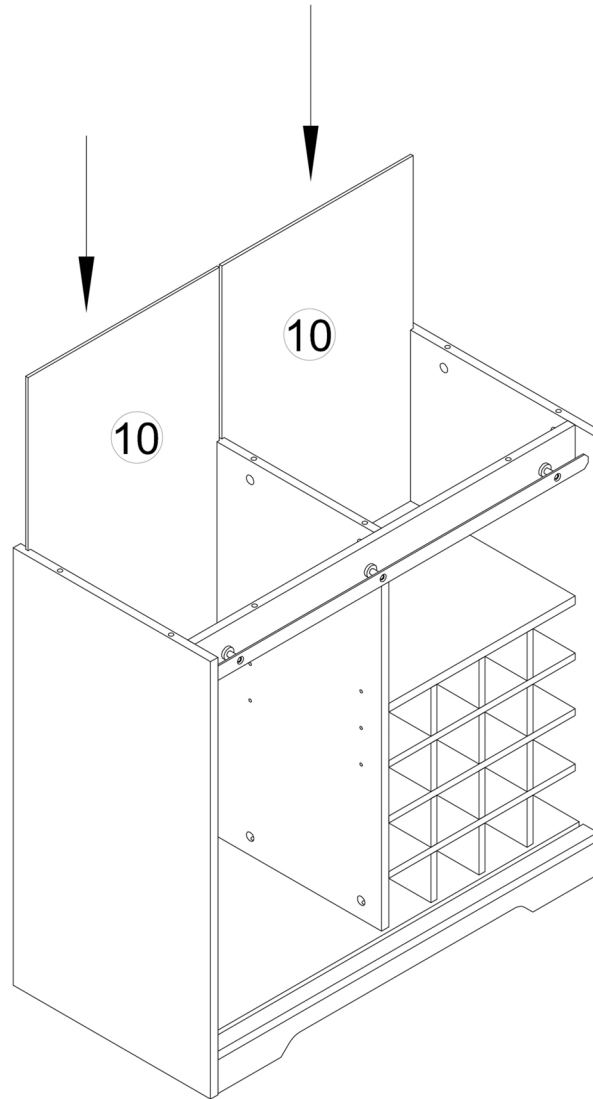

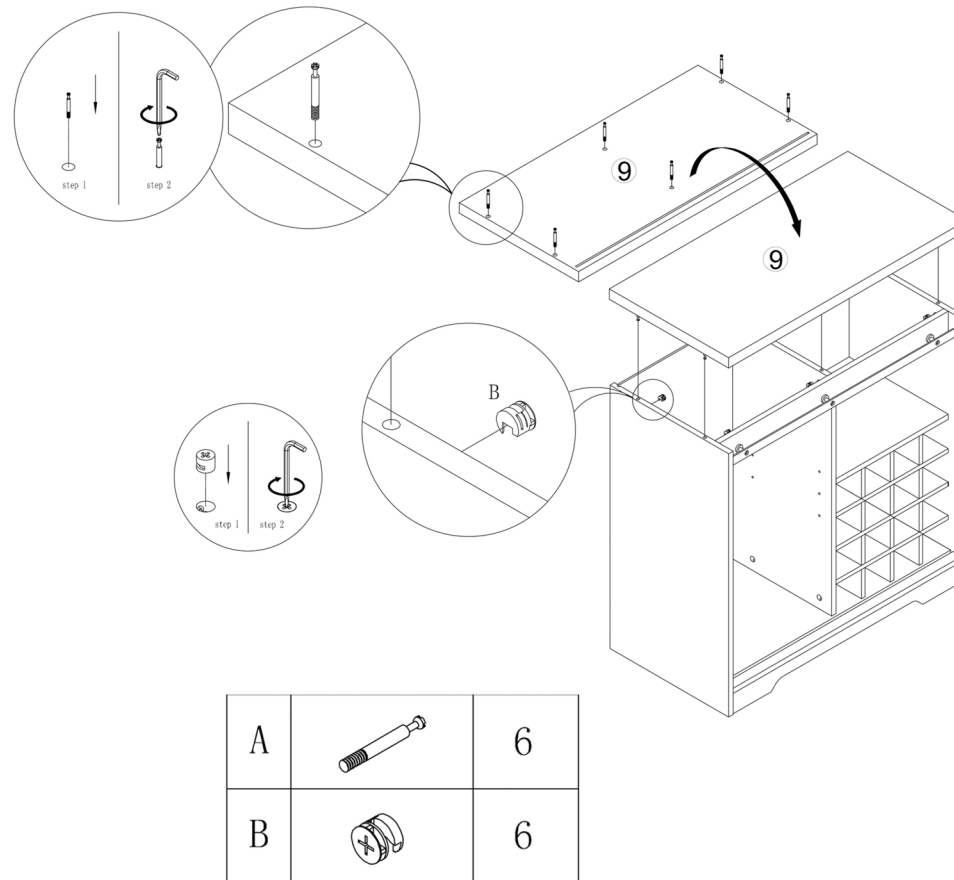

Step 9.
Insert 2PCS Panel 10 into Panel 4,5,6.

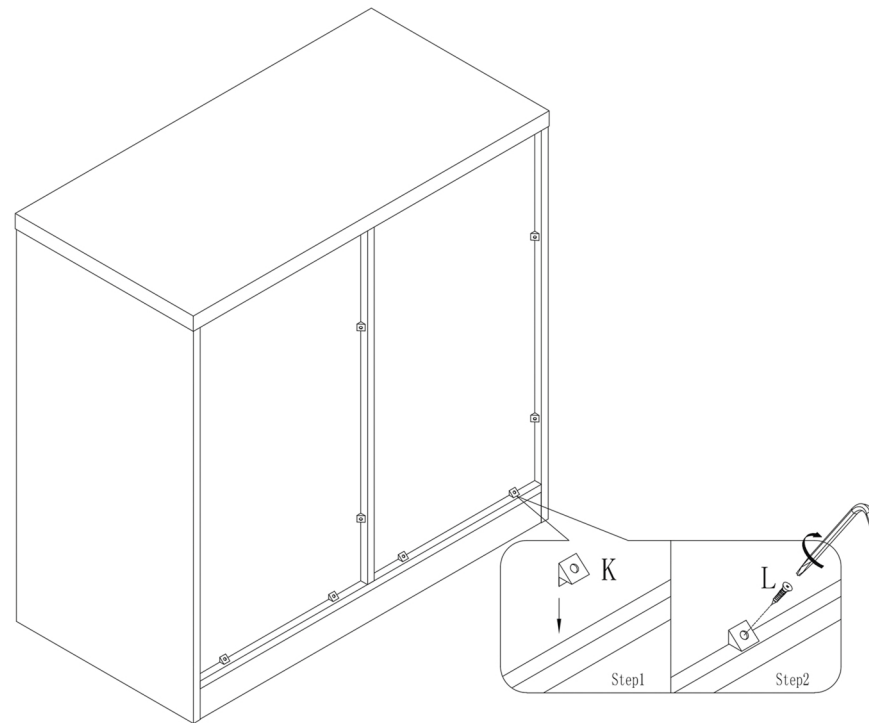

Step 10.
Fix metal part T on cabinet back with Screw O.



K		16
L		16

Step 11.
Fix component K on the cabinet back with Screw L.

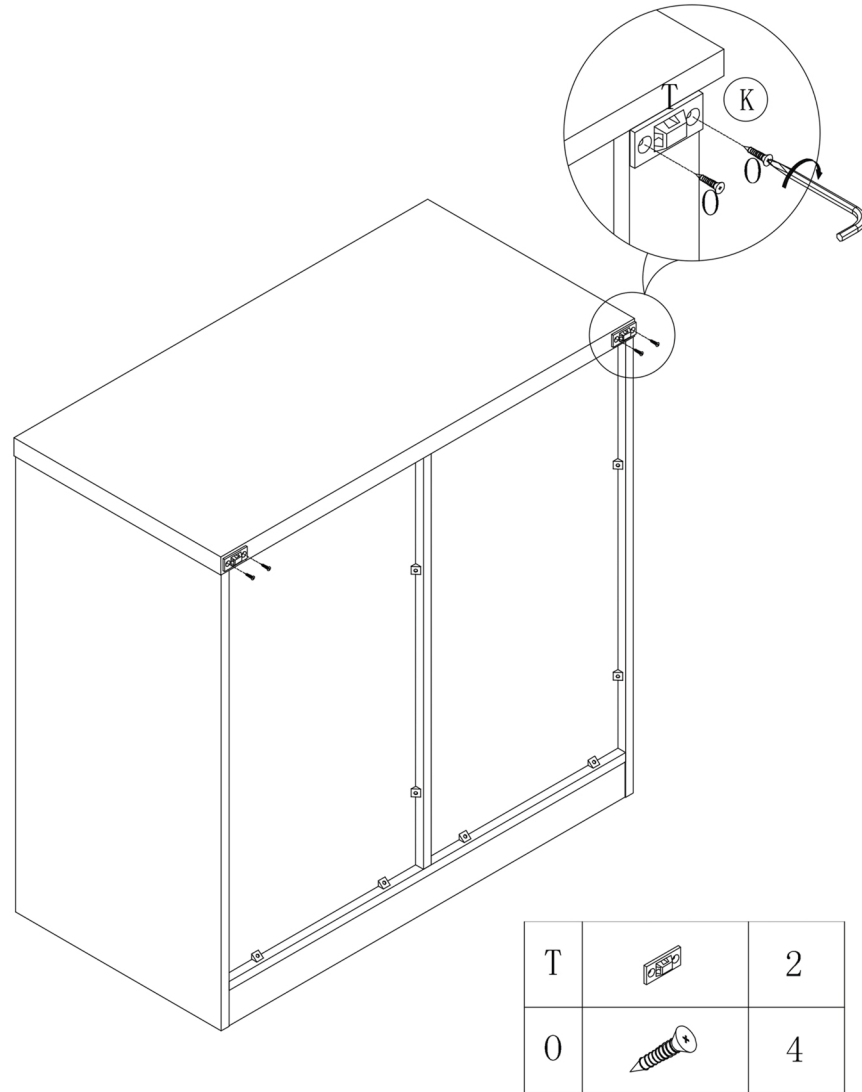

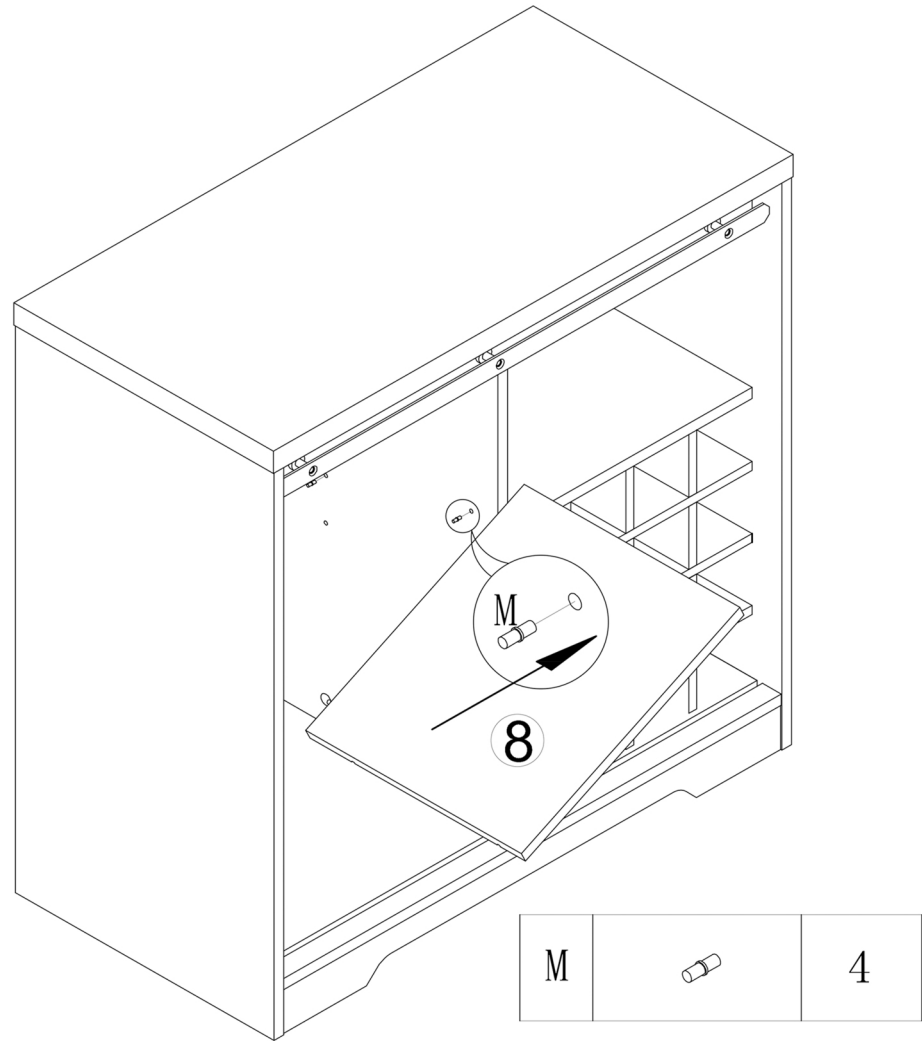

Step 12.
Fix metal part T on cabinet back with Screw O.

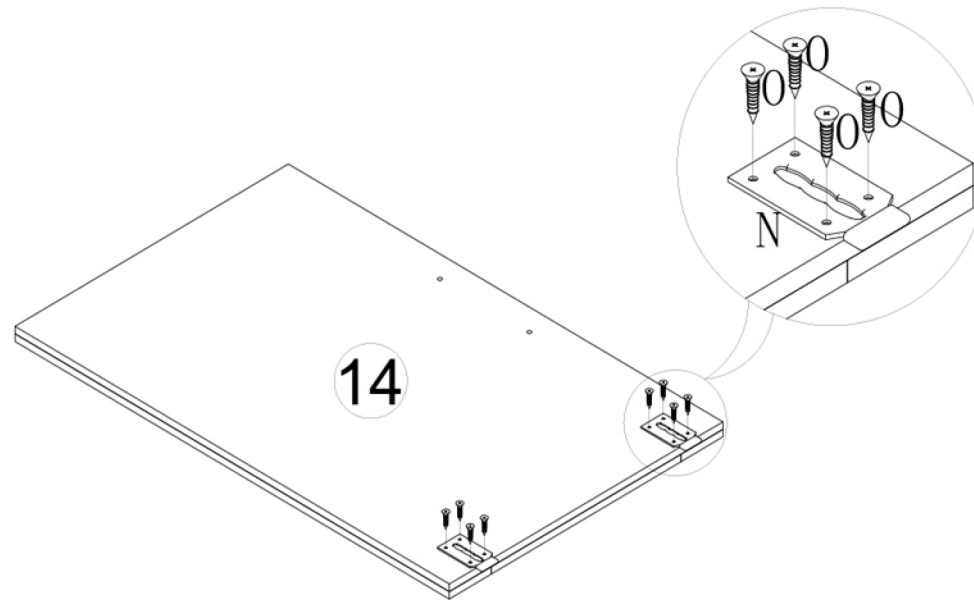

Step 13.
Insert metal part M into the holes on Panel 4,5,
then put Panel 8 on them.



N		2
O		8

Step 14.
Fix metal part N on Panel 14 with Screw O.

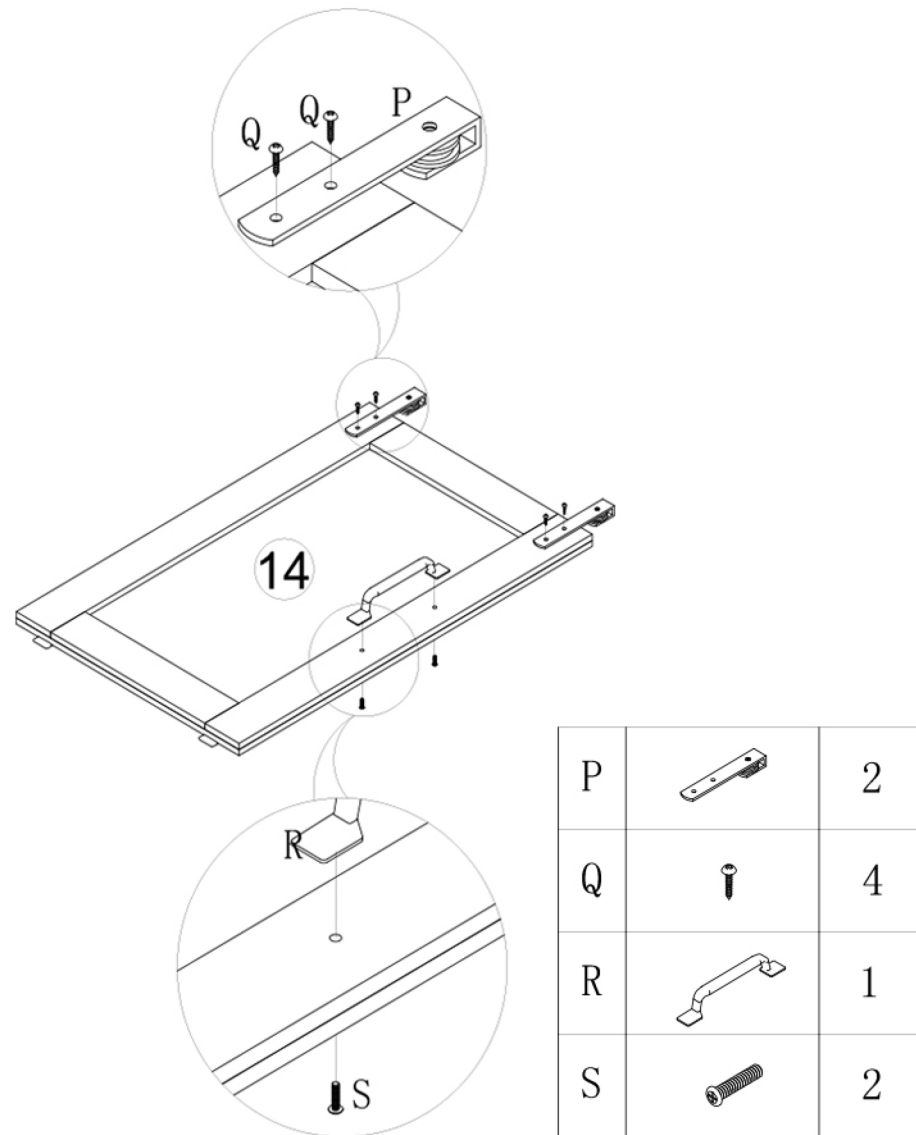

Step 15.

Fix metal part P on Panel 14 with Screw Q.
Fix handle R on the doors Panel 14 with Screw S.

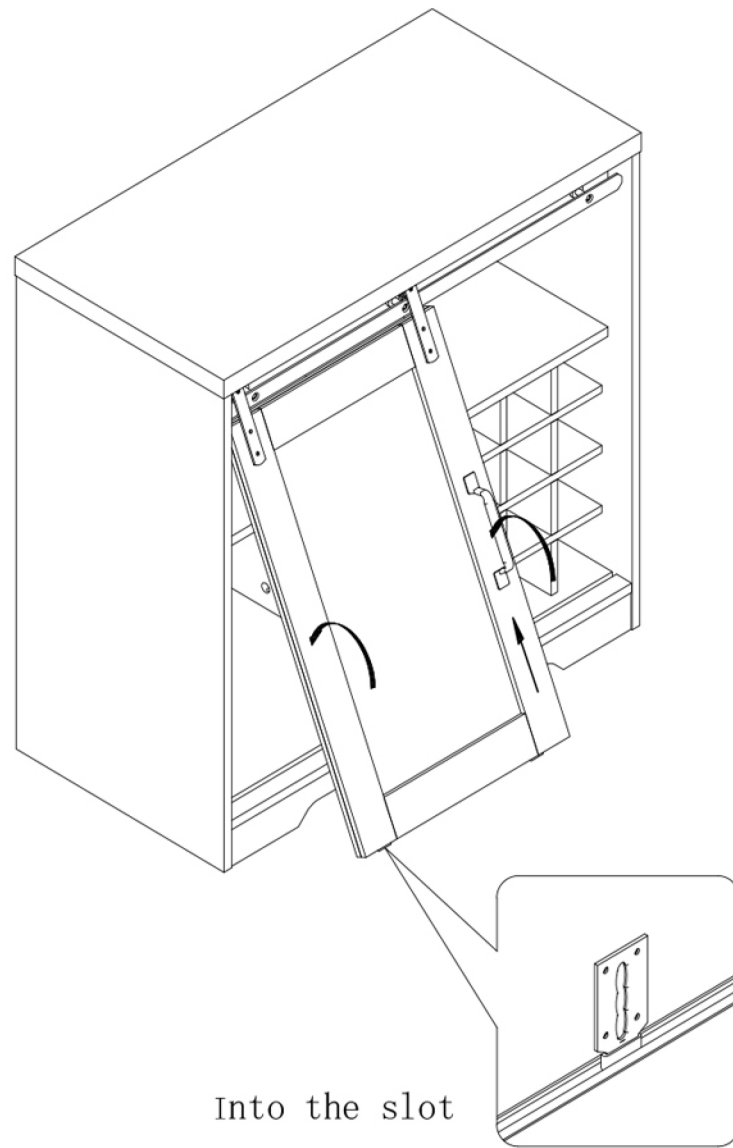

Into the slot

Step 16.

Hang the door on the metal part D. Make sure door bottom into the slot.

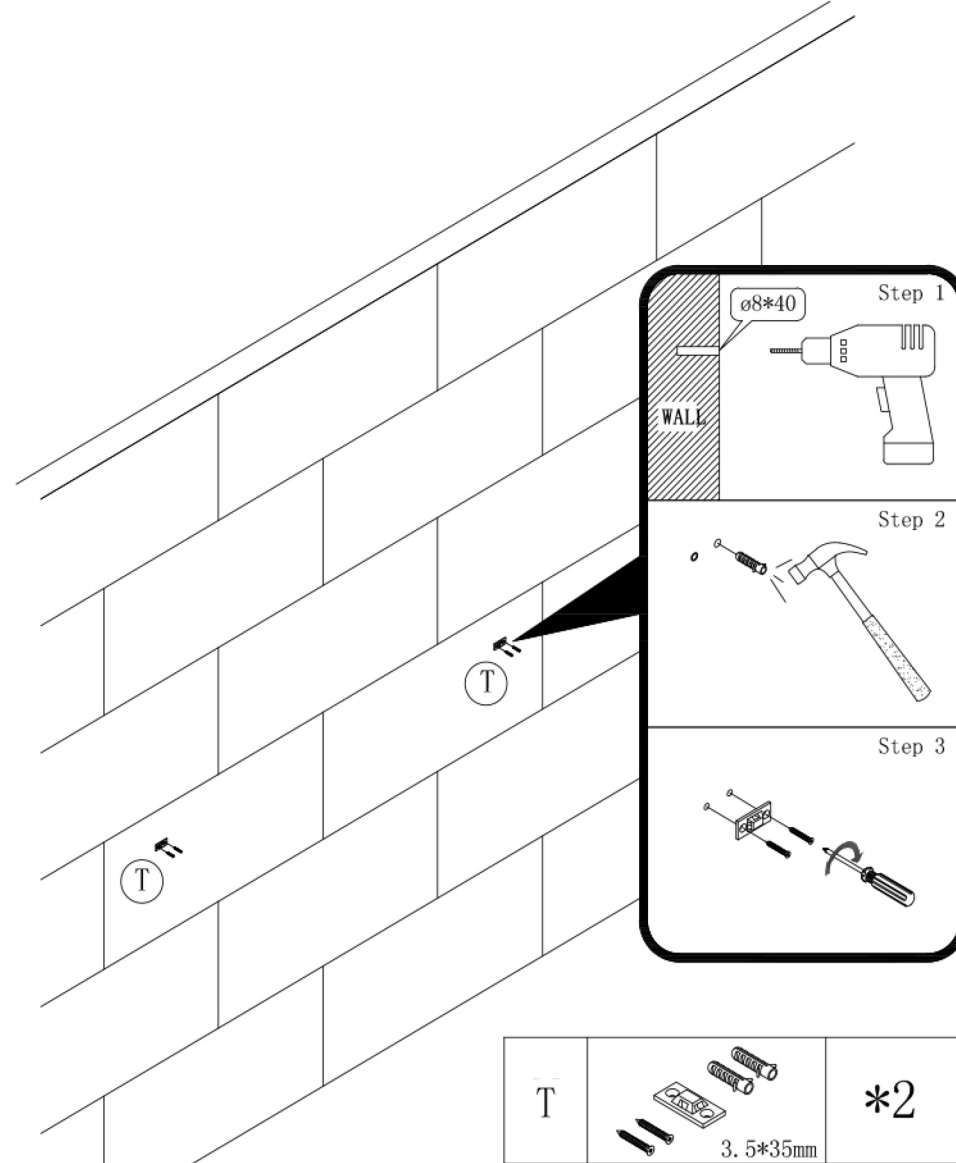

Step 17.
 Drill holes($\phi 8*40$) on the wall at proper position with electric drill,
 Fix T on the wall with hammer and screwdriver.

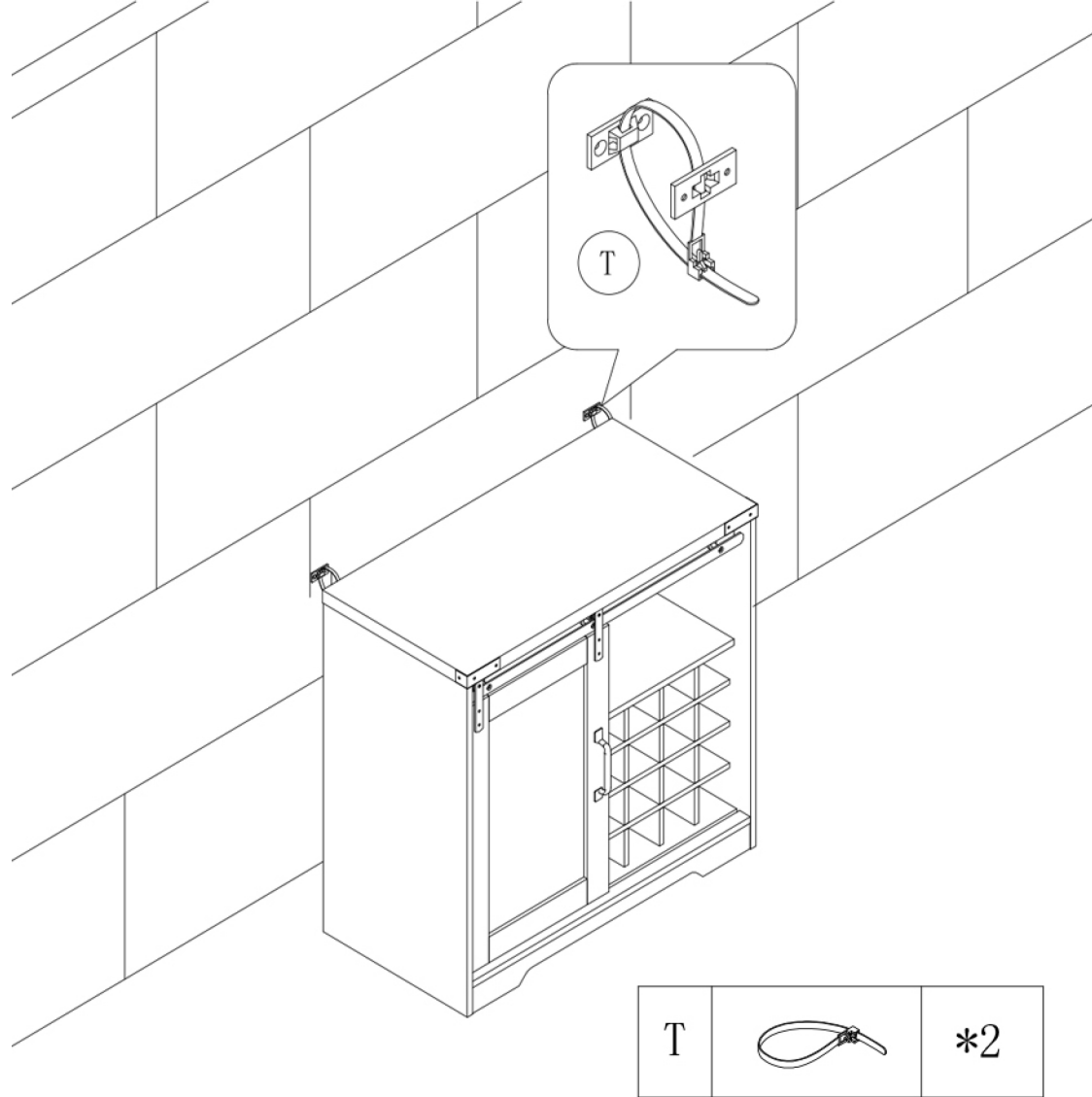

Step 18.
Using ribbon T to tie the cabinet on the wall to avoid falling.